

# RXE 10-16C Technical Data

## Electric Forklift Truck

---

[RXE 10](#)

[RXE 13](#)

[RXE 15](#)

[RXE 16C](#)



# RXE 10-16C Electric Forklift Truck

## Great in the smallest of spaces

This specification sheet, which conforms to VDI guideline 2198, provides the technical values for the standard equipment only. Different tyres, other masts, the use of accessories, etc. may result in other values.



					STILL	STILL	STILL	STILL	
					<b>RXE 10</b>	<b>RXE 13</b>	<b>RXE 15</b>	<b>RXE 16C</b>	
Features	1.1	Manufacturer							
	1.2	Manufacturer's type designation							
	1.2.1	Manufacturer type number			5510	5513	5515	5516	
	1.3	Drive			Electric	Electric	Electric	Electric	
	1.4	Operation			Seated	Seated	Seated	Seated	
	1.5	Capacity/load	Q	kg	1000	1300	1500	1600	
	1.6	Load centre	c	mm	500	500	500	500	
	1.8	Load distance	x	mm	355	355	355	355	
	1.9	Wheel base	y	mm	974	1136	1190	1190	
Weights	2.1	Service weight incl. battery		kg	2455	2717	2867	3022	
	2.2	Axle load, laden	front/rear	kg	2953/502	3459/557	3803/563	3950/672	
	2.3	Axle load, unladen	front/rear	kg	1075/1380	1181/1536	1226/1641	1200/1822	
Wheels	3.1	Tyres			Superelastic	Superelastic	Superelastic	Superelastic	
	3.2	Tyre size	front	mm	180/70-8	180/70-8	180/70-8	180/70-8	
	3.2	Tyre size	rear	mm	180/60-10	180/60-10	180/60-10	180/60-10	
	3.5	Number of wheels (x = driven)	front/rear		2/1x	2/1x	2/1x	2/1x	
Basic dimensions	3.6	Track width	front	b <sub>10</sub>	mm	840	840	840	840
	4.1	Tilt of mast	forward/backward		°	3/5	3/5	3/5	3/5
	4.2	Height of mast	mast retracted	h <sub>1</sub>	mm	2155	2155	2155	2155
	4.3	Free lift		h <sub>2</sub>	mm	150	150	150	150
	4.4	Lift		h <sub>3</sub>	mm	3170	3170	3170	3170
	4.5	Height of mast	mast extended	h <sub>4</sub>	mm	3732	3732	3732	3811
	4.7	Height over overhead guard (cabin)		h <sub>6</sub>	mm	1980	2050	2050	2050
	4.8	Seat height rel. to SIP		h <sub>7</sub>	mm	953	953	953	953
	4.19	Overall length		l <sub>1</sub>	mm	2384	2546	2600	2635
	4.20	Length including fork backs		l <sub>2</sub>	mm	1584	1746	1800	1835
	4.21	Overall width		b <sub>1</sub>	mm	990	990	990	990
	4.22	Fork dimensions		s/e/l	mm	40/80/800	40/80/800	40/80/800	40/80/800
	4.23	Fork carriage ISO 2328, class				ISO II A	ISO II A	ISO II A	ISO II A
	4.24	Fork carriage width		b <sub>3</sub>	mm	980	980	980	980
	4.31	Ground clearance below mast, laden		m <sub>1</sub>	mm	84	84	84	84
	4.32	Ground clearance, centre of wheel base		m <sub>2</sub>	mm	94	94	94	94
	4.34.1	Working aisle width with 1000 x 1200 pallet crossways		A <sub>st</sub>	mm	2911	3073	3127	3162
	4.34.2	Working aisle width with 800 x 1200 pallet lengthways		A <sub>st</sub>	mm	3035	3197	3251	3286
	4.35	Turning radius		W <sub>a</sub>	mm	1229	1391	1445	1480
	Performance data	5.1	Driving speed	laden/unladen	km/h	12.0/12.5	12.0/12.5	12.0/12.5	12.0/12.5
5.2		Lifting speed	laden/unladen	m/s	0.42/0.52	0.36/0.52	0.33/0.52	0.32/0.52	
5.3		Lowering speed	laden/unladen	m/s	0.51/0.51	0.51/0.51	0.51/0.51	0.51/0.51	
5.5		Drawbar pull	laden/unladen	N	1911/2121	1947/2216	1729/2032	1676/2004	
5.6		Max. drawbar pull	laden/unladen	N	2399/6919	3529/7062	3498/7008	4329/7033	
5.7		Gradeability	laden/unladen	%	6.1/9.5	4.95/8.4	4.4/7.8	4/7.3	
5.8		Max. gradeability	laden/unladen	%	20.9/31	17.6/27.56	16/25.8	14.9/24.4	
5.9		Acceleration time 15 m	laden/unladen	s	6.9/6	7/6.2	7.7/6.3	7.7/6.6	
5.10		Service brake				Hydraulic	Hydraulic	Hydraulic	Hydraulic
Electric engine		6.1	Drive motor, output with S3 60 min		kW	4.9	4.9	4.9	4.9
	6.2	Lifting motor, output at S3 15% d.c.		kW	7.6	7.6	7.6	7.6	
	6.3	Battery according to DIN 43531/35/36 A, B, C, no			DIN 43535 A	DIN 43535 A	DIN 43535 A	DIN 43535 A	
	6.4	Battery voltage	U	V	24	24	24	24	
	6.4.1	Battery capacity	K <sub>5</sub>	Ah	500	875	1000	1000	
	6.5	Battery weight		kg	372	600	676	676	
	6.6	Energy consumption according to EN 16796		kWh/h	2.46	2.9	3.1	3.32	
	6.7	Turnover output		t/h	62.6	80.1	90.7	99.4	
Misc.	6.8	Fuel consumption at turnover output		kWh/h	3.61	4	4.2	4.39	
	10.1	Operating pressure for attachments		bar	170	200	220	220	
	10.2	Oil volume for attachments		l/min	23	20	18	18	
	10.7	Sound pressure level L <sub>pAZ</sub> (operator's position) <sup>1</sup>		dB(A)	60.0	60.0	60.0	60.0	
10.7.1	Human vibrations: acceleration in accordance with EN 13059		m/s <sup>2</sup>	0.54	0.54	0.54	0.54		

<sup>1</sup> Without cab; different values with cab

RXE 10-16C Electric Forklift Truck  
 Technical Drawings

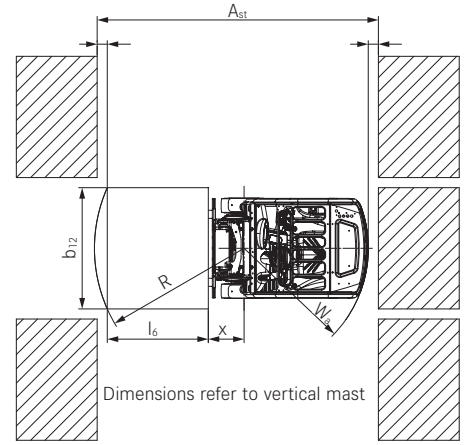
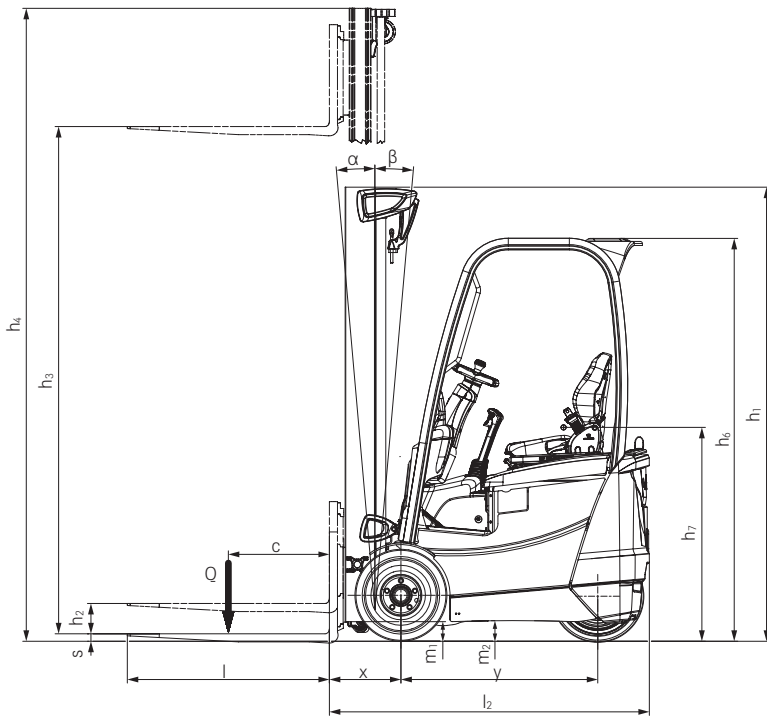

RXE side view

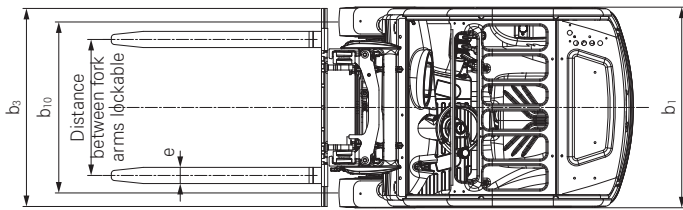

RXE top view

Truck Widths

Tyres		Truck width $b_1$	Track front $b_{10}$
Superelastic 180/70-8	mm	990	840
Superelastic 180/70-8	mm	1028	872

RXE 10-16C Electric Forklift Truck  
Mast Tables



		Telescopic mast										HiLo mast					Triplex mast						
RXE 10 / RXE 13 / RXE 15	Nominal lift	$h_3$	mm	2770	2970	3170	3470	3870	4170	4670	5370	2950	3150	3350	3550	3950	4310	4610	4910	5210	5610	6060 <sup>4</sup>	6810 <sup>5</sup>
	Height	$h_1$	mm	1955	2055	2155	2305	2505	2655	2905	3255	1950	2050	2150	2250	2450	1950	2050	2150	2250	2450	2600 <sup>4</sup>	2850 <sup>5</sup>
	Free lift <sup>1,2</sup>	$h_2$	mm	150	150	150	150	150	150	150	150	1406	1506	1606	1706	1906	1406	1506	1606	1706	1906	2056	2306
	Height, mast raised <sup>1,2</sup>	$h_4$	mm	3332	3532	3732	4032	4432	4732	5232	5932	3508	3708	3908	4108	4508	4874	5174	5474	5774	6174	6624	7374
	Tilt angle	forward/backward	$\alpha/\beta$	°	3/5										3/5								
	Fork lock-in position centre-centre			mm	216/368/445/521/673/760																		
	Tyres	front/rear			180/70-8 / 180/60-10					180/70-8 / 180/60-10					180/70-8 / 180/60-10								
	Track	front/rear	$b_{10}/b_{11}$	mm	840/0					840/0					840/0								
	Maximum width		$b_1$	mm	990					990					990								
			Telescopic mast										HiLo mast					Triplex mast					
RXE 16C	Nominal lift	$h_3$	mm	2770	2970	3170	3470	3870	4170	4670	5370	2950	3150	3350	3550	3950	4310	4610	4910	5210	5610	6060	6810
	Height	$h_1$	mm	1955	2055	2155	2305	2505	2655	2905	3255	1950	2050	2150	2250	2450	1950	2050	2150	2250	2450	2600	2850
	Free lift <sup>1,2</sup>	$h_2$	mm	150	150	150	150	150	150	150	150	1352	1452	1552	1652	1852	1352	1452	1552	1652	1852	2002	2252
	Height, mast raised <sup>1,2</sup>	$h_4$	mm	3411	3611	3811	4111	4511	4811	5311	6011	3562	3762	3962	4162	4562	4928	5228	5528	5828	6228	6678	7428
	Tilt angle	forward/backward	$\alpha/\beta$	°	3/5										3/5								
	Fork lock-in position centre-centre			mm	216/368/445/521/673/760																		
	Tyres	front/rear			180/70-8 / 180/60-10					180/70-8 / 180/60-10					180/70-8 / 180/60-10								
	Track <sup>3</sup>	front/rear	$b_{10}/b_{11}$	mm	840/0					840/0					840/0								
	Maximum width		$b_1$	mm	990					990					990								

<sup>1</sup> Fork carriage ISO II A standard

<sup>2</sup> Deviations depending on 4/6-roll fork carriages

<sup>3</sup> Wider track available for higher basic load capacity, track 872 with truck width  $b_1 = 1028$  mm

<sup>4</sup> Only for RXE 13 and RXE 15

<sup>5</sup> Only for RXE 15

# RXE 10-16C Electric Forklift Truck

## Basic Load Capacities

RXE 10 Telescopic mast - superelastic single tyres 180/70-8, Truck width 990 mm + 1028 mm

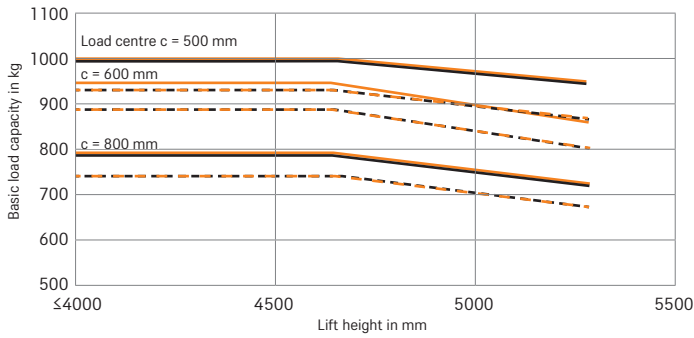

RXE 10 Triplex mast - superelastic single tyres 180/70-8, Truck width 990 mm + 1028 mm

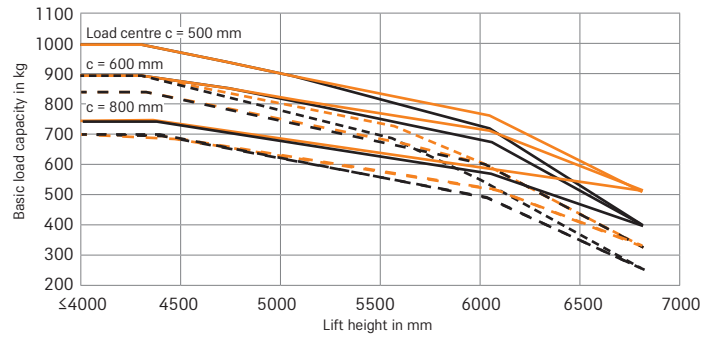

RXE 13 Telescopic mast - superelastic single tyres 180/70-8, Truck width 990 mm + 1028 mm

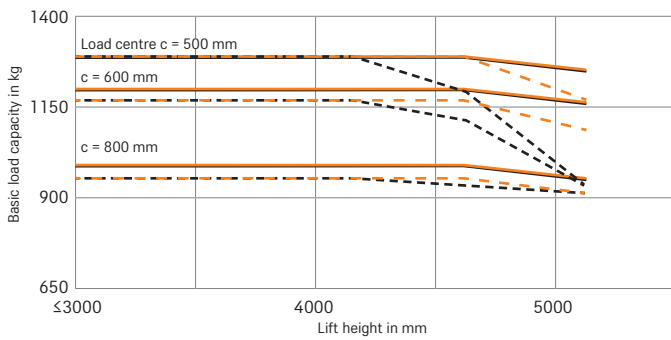

RXE 13 Triplex mast - superelastic single tyres 180/70-8, Truck width 990 mm + 1028 mm

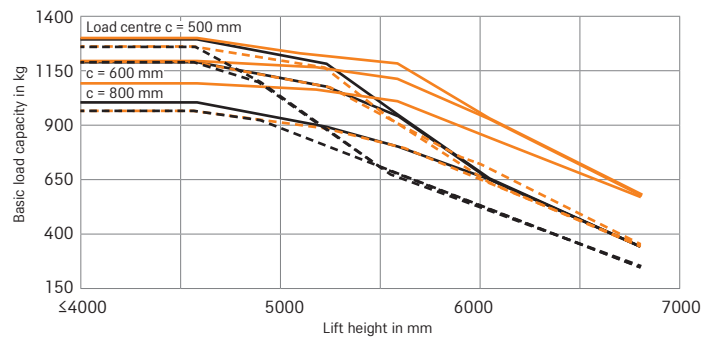

RXE 15 Telescopic mast - superelastic single tyres 180/70-8, Truck width 990 mm + 1028 mm

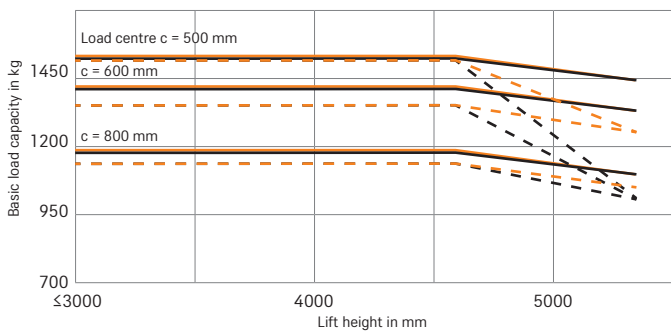

RXE 15 Triplex mast - superelastic single tyres 180/70-8, Truck width 990 mm + 1028 mm

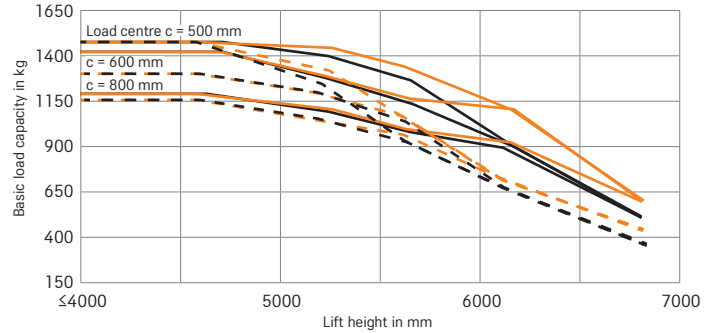

RXE 16C Telescopic mast - superelastic single tyres 180/70-8, Truck width 990 mm + 1028 mm

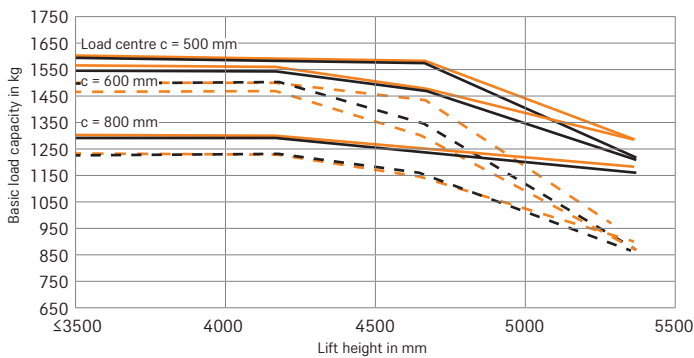

RXE 16C Triplex mast - superelastic single tyres 180/70-8, Truck width 990 mm + 1028 mm

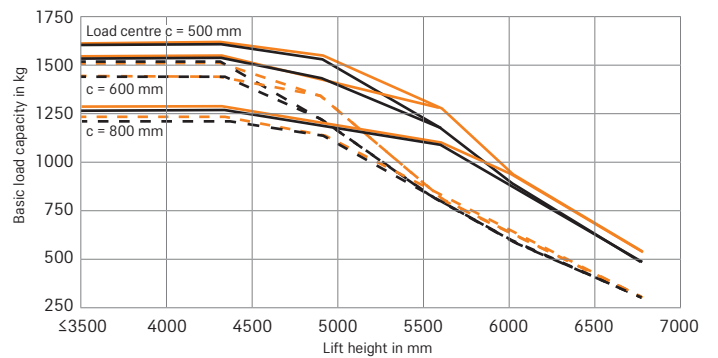

990 mm + LC 500     
  990 mm + LC 500     
  1028 mm + LC 500  
 990 mm + LC 600     
  990 mm + LC 600     
  1028 mm + LC 600  
 990 mm + LC 800     
  990 mm + LC 800     
  1028 mm + LC 800

1028 mm + LC 500  
 1028 mm + LC 600  
 1028 mm + LC 800

With standard forks     
  With integrated side shifter and standard forks  
 The listed values may vary depending on the truck's features.

## RXE 10-16C Electric Forklift Truck Detailed Photos



Perfection in confined spaces: compact truck dimensions and extremely high manoeuvrability allow for working in narrow aisles



Everything safely in view: the slim mast allows operators to have the best possible view of the forks and goods



Compact on the outside, comfortable on the inside: ergonomic and clearly laid out driver's workspace ensuring a pleasant working environment



Optimal all-round visibility thanks to slim mast and visibility-optimised protected roof bars



Both battery and drive are easily accessible – for maximum availability and convenient maintenance



To provide an ergonomic workplace and comfortable access, the RXE has a spacious footwell despite its compact dimensions

RXE 10-16C Electric Forklift Truck  
Great in the smallest of spaces





### Simply easy

---

- Familiar, intuitive handling thanks to the uniform operating concept across the RX electric forklift truck family
- Relevant information and performance functions clearly available in the STILL Easy Control on-board computer
- Perfection in confined spaces: compact truck dimensions and extremely high manoeuvrability allow for working in narrow aisles
- Always available thanks to the lateral quick-charge access for optional lithium-ion batteries
- Systematic safety thanks to the (optional) daily pre-shift check in the display
- Maximum safety at work thanks to individually configurable equipment options – from indicators to Safety Light 4Plus safety lighting and curve speed control
- Safe load handling thanks to numerous assistance functions such as lift height display and overload detection



### Simply powerful

---

- Powerful and reliable thanks to maintenance-free rotary current drive in 24 V technology
- Impressive productivity thanks to a lifting capacity of up to 1.6 tonnes with a load centre of 500 mm
- Effective material handling thanks to a maximum driving speed of 12 km/h when laden
- Supports the driver with smart assistance functions
- Ready at all times thanks to the optional lithium-ion technology



### Simply safe

---

- Safe and precise handling: high-precision hydraulics and agile driving dynamics
- Optimal all-round visibility thanks to slim mast and visibility-optimised protected roof bars



### Simply flexible

---

- Individual control options for optimal driver comfort: multi-lever, mini-lever, Fingertip or Joystick 4Plus
- Perfect for any application thanks to a flexible portfolio with a wide range of equipment options
- Flexible use in forklift truck fleets thanks to the uniform operating concept across the RX series: drivers can switch between RXE 10-16C, RX 20 and RX 60 easily and without training time



### Simply connected

---

- Can be optimally networked via an optional interface, which allows for uncomplicated integration into fleet management systems such as STILL neXXt fleet
- Controlled use and protection against incorrect operation thanks to optional access control

# Simply Efficient





## RXE 10-16C Electric Forklift Truck Great in the smallest of spaces

Sensationally slim dimensions of just under 2 metres high and 1 metre wide

Safe storage and retrieval at maximum height thanks to the extra stable mast design, low centre of gravity and modern assistance systems

Drive as if you were on rails, even with dynamic cornering, thanks to curve speed control

Innovative operating concept of the RX electric forklift family and smart STILL Easy Control on-board computer



Turn it any way you want, the RXE 10-16C simply fits. Always. The youngest and smallest member of the electrifying STILL electric forklift truck family is one of the greatest in terms of performance: compact as it is, it shines with a perfect balance of driving comfort, manoeuvrability and safety – even when things get really tight. Be it in HGVs, containers or narrow aisles, the RXE 10-16C is incomparably efficient and agile in the smallest of spaces thanks to its compact dimensions and sensitive steering. And that is precisely why it is so versatile. Whether it is in the food industry, at logistics service providers, in production supply or in joint warehouses of large retailers, the compact three-wheel counterbalanced forklift truck inspires as an efficient helper for loading and unloading HGVs or containers as well as for transporting pallets

in the warehouse. With a top speed of 12.5 km/h, it gets a lot done very quickly. And to ensure that not a single moment of its electrifying dynamics is lost for safety reasons, it is equipped with the proven Curve Speed Control as standard. This keeps you safely on track at all times – even in the tightest of curves. So when it comes to moving 1.0 to 1.6 tonnes in a space-saving way, the RXE 10-16C is the perfect choice! With its wide range of equipment options and assistance systems, it is also an attractive upgrade from the high lift stackers, with increased comfort and added safety. All this makes it the perfect successor to the legendary STILL RX 50, one of the best-selling electric forklift trucks in its class ever. Proof that the RXE 10-16C fits the bill. Always.



# RXE 10-16C Electric Forklift Truck

## Equipment Variants



	RXE 10	RXE 13	RXE 15	RXE 16C	
Operator's cab	Standard protective roof (without window)	●	●	●	●
	Overhead guard height 1980 mm for low passages	●	○	○	○
	Overhead guard height 2050 mm for container loading	—	●	●	●
	Weather protection or tarpaulin cab	—	○	○	○
	Tinted front windscreen, roof windows made of either green-tinted or Makrolon laminated safety glass, plus windscreen wiper/washer system	○	○	○	○
	Drive-in overhead guard	—	○	○	○
	One-pedal control, switching the direction of travel using the hydraulic control	●	●	●	●
	Dual-pedal control	○	○	○	○
	Built-in storage for mobile phone and cup holder	●	●	●	●
	12 V power connection and 5 V USB connection	○	○	○	○
	Writing pad with clipboard, illuminated (removable)	○	○	○	○
	MSG 65 Grammer seat with leatherette cover	●	●	●	●
	MSG 65 Grammer Exclusiv PLUS with leatherette cover; extra-wide seat cushion, high suspension travel, lumbar support, height-adjustable back extension and heated seat	○	○	○	○
	Document pocket on the seat back	○	○	○	○
	Horizontal spring plate for driver's seat to minimise human vibrations	○	○	○	○
	Mast	Grab handle on front of protected roof	●	●	●
STILL Easy Control splash-proof colour display with intuitive menu navigation		●	●	●	●
Storage box above the counterweight		—	—	○	○
Load backrest		○	○	○	○
Mast vertical position		○	○	○	○
Mast with 'Silent Mast' reach damping system and end cushioning with mechanical or electrical fork wear protection		○	○	○	○
Sensor-based display of lift height and indication in STILL Easy Control display		○	○	○	○
Display showing tilt angle and cushioned lowering in the tilt end positions		○	○	○	○
Load measurement and overload detection with suppression of the lifting function		○	○	○	○
Proportional valve technology for especially sensitive movements		○	○	○	○
Hydraulics	Multi-lever operation	●	●	●	●
	Armrest with mini levers (2, 3 or 4 levers), Fingertip or Joystick 4Plus	○	○	○	○
	Food variant with special hydraulic oil	○	○	○	○
	Cold store variant with special low-temperature oil	○	○	○	○
Drive	Low operating costs due to low energy consumption	●	●	●	●
	Blue-Q energy-saving mode	●	●	●	●
	Display showing energy consumption and remaining driving time based on current charge	●	●	●	●
	Maintenance-free drives for driving, steering and lifting	●	●	●	●
	Enclosed components to protect against dust and damp	●	●	●	●
	Operating hours counter only operational with drive and lifting motor	●	●	●	●
	Lithium-ion battery with quick-charge access from the side	○	○	○	○
Brake	Energy recovery when braking	●	●	●	●
	Mechanical parking brake	●	●	●	●
Safety	EasyBelt restraint system for quick and safe fastening and unfastening	○	○	○	○
	Headlights and lighting in LED design	○	○	○	○
	LED floodlights on the mast	○	○	○	○
	Driver-adjusted speed limiter	○	○	○	○
	STILL Safety Light 4Plus warning device	○	○	○	○
	Safety zone light: warning light bars to the left, right and rear of the truck	○	○	○	○
	Curve Speed Control	●	●	●	●
	Speed limited when fork carriage is raised	○	○	○	○
	Panoramic mirror	○	○	○	○
	Direction can be changed both left- and right-handed via mini console	○	○	○	○
	FleetManager: access authorisation, shock detection, reports	○	○	○	○
	Pre-shift check in the display for a guided safety check before the truck can be operated	○	○	○	○
	Intelligent seat belt control	●	●	●	●
	Dynamic Load Control 1 and 2 stability assistants for safe load handling	○	○	○	○
Pre-configured for use on public roads	○	○	○	○	

● Standard ○ Option — Not available



STILL GmbH  
Berzeliusstr. 10  
22113 Hamburg  
Germany

Tel.: +49 40 73 39 20 00

Fax: +49 40 73 39 20 01

info@still.de

**For further information please visit**

**[www.still.eu](http://www.still.eu)**

STILL is certified in the following areas: Quality management, occupational safety, environmental protection and energy management.



**first in intralogistics**